

STC20.20
STC40.20
STC60.20

SNAP TRACK

Aluminum Cable Tray System

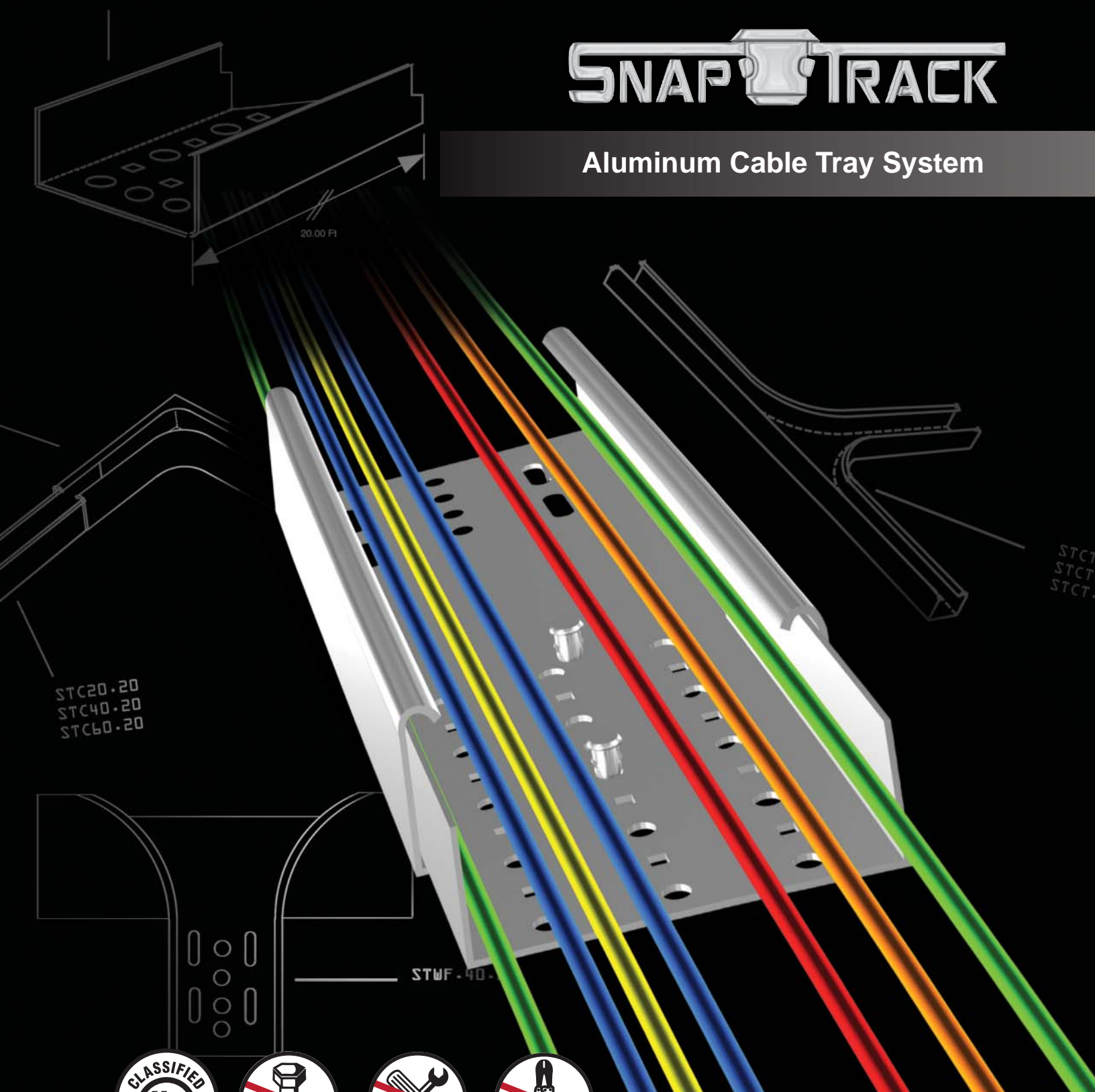

STC20.20
STC40.20
STC60.20

STC
STC
STC

STWF-40



**Save on Total
Installed Costs**

TechLine[®] MFG. ... *Supporting future industry today*

• Complete Cable Tray System

The Snap Track System protects your cables from the control room to the instrument and all points in between, including drops, brick panels and at the instrument stand.

• UL Classified

Snap Track products are UL Classified as an EGC, as well as manufactured to meet current NEMA and NEC Standards.

• Ease of Installation

The Snap Track System is designed to be installed without bolts or tools using a patented push pin.

• Superior Strength

Solid side rail fittings with inward "C" configuration provide superior strength, support and cable protection.

• Quality Tested

Snap Track products are designed, manufactured and quality tested to the tightest tolerances in the industry by using extruded construction.

• On Site Training Included for Projects

Save on total installed cost using labor-saving Snap Track cable trays.

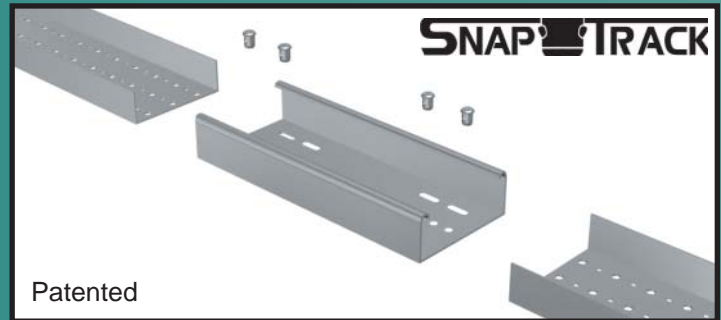

Channel

2" STC-2-2-AL
4" STC-4-2-AL
6" STC-6-2-AL

Straight Splice

2" STCS-2-2-AL
4" STCS-4-2-AL
6" STCS-6-2-AL

Adjustable Splices

2" STAVS-2-2-AL
4" STAVS-4-2-AL
6" STAVS-6-2-AL

2" STAHS-2-2-AL
4" STAHS-4-2-AL
6" STAHS-6-2-AL

Short Radius Elbows

2" STHE-2-2-AL-3R/6R
4" STHE-4-2-AL-3R/6R
6" STHE-6-2-AL-3R/6R

2" STVI-2-2-AL-3R/6R
4" STVI-4-2-AL-3R/6R
6" STVI-6-2-AL-3R/6R

2" STVO-2-2-AL-3R/6R
4" STVO-4-2-AL-3R/6R
6" STVO-6-2-AL-3R/6R

*3" Radius Pictured

Short Radius Channel Tee

2" STCT-2-2-AL-3R/6R
4" STCT-4-2-AL-3R/6R
6" STCT-6-2-AL-3R/6R

Short Radius Channel Cross

2" STCC-2-2-AL-3R/6R
4" STCC-4-2-AL-3R/6R
6" STCC-6-2-AL-3R/6R

Covers & Cover Clamps

2" STCV-2-AL
4" STCV-4-AL
6" STCV-6-AL

2" STCC2-2-C/F
4" STCC4-2-C/F
6" STCC6-2-C/F

Divider Strips

STDS-1-1.5-AL

Long Radius Horizontal Elbow



2" STHE-2-2-AL-12R/24R/36R
4" STHE-4-2-AL-12R/24R/36R
6" STHE-6-2-AL-12R/24R/36R

Long Radius Vertical Outside Elbow



2" STVO-2-2-AL-12R/24R/36R
4" STVO-4-2-AL-12R/24R/36R
6" STVO-6-2-AL-12R/24R/36R

Long Radius Vertical Inside Elbow



2" STVI-2-2-AL-14R/24R/36R
4" STVI-4-2-AL-14R/24R/36R
6" STVI-6-2-AL-14R/24R/36R

Long Radius Channel Tee



2" STCT-2-2-AL-12R/24R/36R
4" STCT-4-2-AL-12R/24R/36R
6" STCT-6-2-AL-12R/24R/36R

Long Radius Channel Cross



2" STCC-2-2-AL-12R/24R/36R
4" STCC-4-2-AL-12R/24R/36R
6" STCC-6-2-AL-12R/24R/36R

Waterfall Exit



STWF-2-2-AL-6R
STWF-4-2-AL-6R

Ladder Tray Transitions

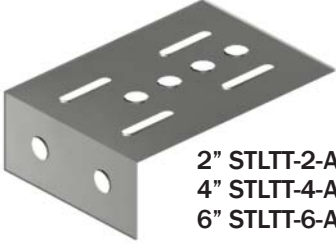

2" STLTT-2-AL
4" STLTT-4-AL
6" STLTT-6-AL

*See website for full list of parts and configurations.

Bonding Jumpers

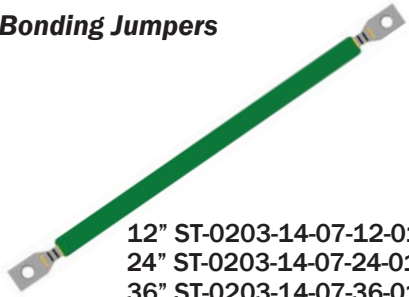

12" ST-0203-14-07-12-01
24" ST-0203-14-07-24-01
36" ST-0203-14-07-36-01

*Other lengths available on request.

Grounding Clamps



STCTG-250

Conduit Bracket



STCB-AL

Wire Clamps

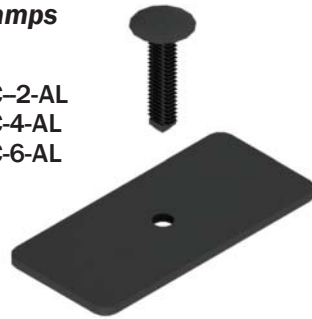

2" STWC-2-AL
4" STWC-4-AL
6" STWC-6-AL

Standard & Custom Instrument Stands



Hanger Bracket

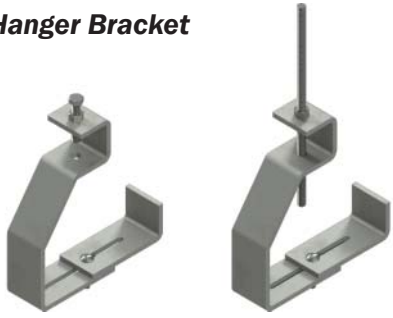

STHB-4-6-AL-XX

Post Base



2" STFPB-2-AL
4" STFPB-4-AL
6" STFPB-6-AL

Perforated Angle



STA-2-2-AL

Snap Track: The Complete System

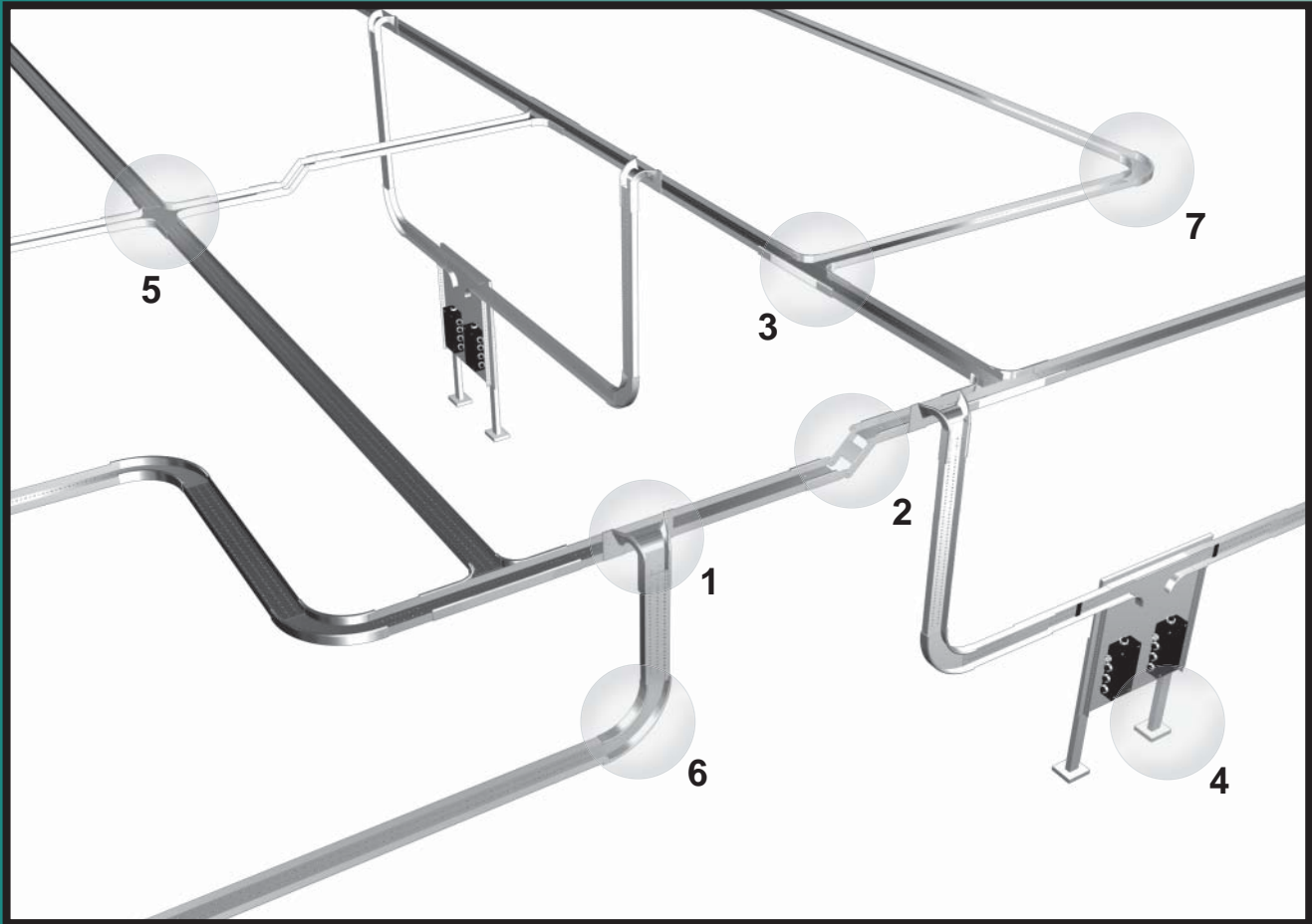

Snap Track Fittings

1. Snap Track Water Fall Exit
2. Snap Track Adjustable Splice
3. Snap Track Tee
4. Snap Track Post Base
5. Snap Track Cross
6. Snap Track Long Radius Elbow
7. Snap Track Horizontal Elbow

For more information regarding Snap Track or to request a complete catalog, please contact TechLine Manufacturing.

TechLine Manufacturing

Corporate Office and Factory

30516 Sgt. E.I. Boots Thomas Dr. • Spanish Fort, AL 36527
Toll Free: 1-800-395-3369 • Local 251-380-7300 • Fax 251-380-7301

www.techlinemfg.com

TechLine Manufacturing

Regional Service Center

11810 W Fairmont Pkwy. • La Porte, TX 77571
Toll Free: 1-800-395-3369 • Fax 832-284-4798

www.techlinemfg.com

TechLine[®]
MFG.

TechLine Mfg. Snap Track 2018